

REVISIONS				
REV	ECN	DESCRIPTION	DATE	APP'D
M		AQ-MATIC UPDATE & VERIFIED PART NUMBERS	1/20/2017	MGS
N		PUT LOGO ON VALVE BODY, CORRECT MINOR ERRORS	8/16/2018	KJB
P	1716	EXTERNAL REFERENCE REDRAW, REM'D 1073557 & 1071827, SECTION HATCHING UPDATE, BOM REORDERED	7/21/2020	PMJ
R	1908	ADDED BALLOON TO END RETAINER O-RING (7)	6/9/2021	PMJ

BILL OF MATERIALS				
ITEM	PART NO	MODEL	DESCRIPTION	QTY
1	1073344	V534-410K	VALVE BODY	1
2	1073330	V534-093	PLATE, DISC, 534, PVC, MCHD	1
3	1073337	V534-110	DISC, 534	EPDM
	1073339	V534-112		FKM
	1073338	V534-111		BUTYL
4	1073353	V534-500	DISC HOLDER, 534	1
28	1071745	ORE-212	O-RING, 2-212	EPDM
	1071816	ORV-212		FKM
	1071777	ORJ-212		BUTYL
6	1073350	V534-491	GUIDE, SHAFT, 534	1
7	1071751	ORE-228	O-RING, 2-228	EPDM
	1071822	ORV-228		FKM
	1071781	ORJ-228		BUTYL
8	1073375	V534-593	RING, RETAINING, 534	1
9	1073360	V534-533	SHAFT, 534	1
10	1071709	ORB-240	O-RING, 2-240	BUNA N 1
29	1073458	V537-080K	NUT, RETAINING, 537, NORYL	1
12	1071707	ORB-235	O-RING, 2-235	BUNA N 1
13	1073333	V534-100	DIAPHRAGM, SERIES 534	1
14	1073318	V534-040	PLATE, DIAPHRAGM, UPR, 534	1
15	1073317	V534-020K	CAP, VALVE, 534	1
16	1076766	ORB-214	O-RING (NITRILE), 2-214	BUNA N 1
17	1073320	V534-045	PLATE, DIAPHRAGM, LWR, 534	1
18	1073366	V534-551K	SUPPORT, DIAPHRAGM, 534	1
19	1073329	V534-080K	NUT, RETAINING, 534	2

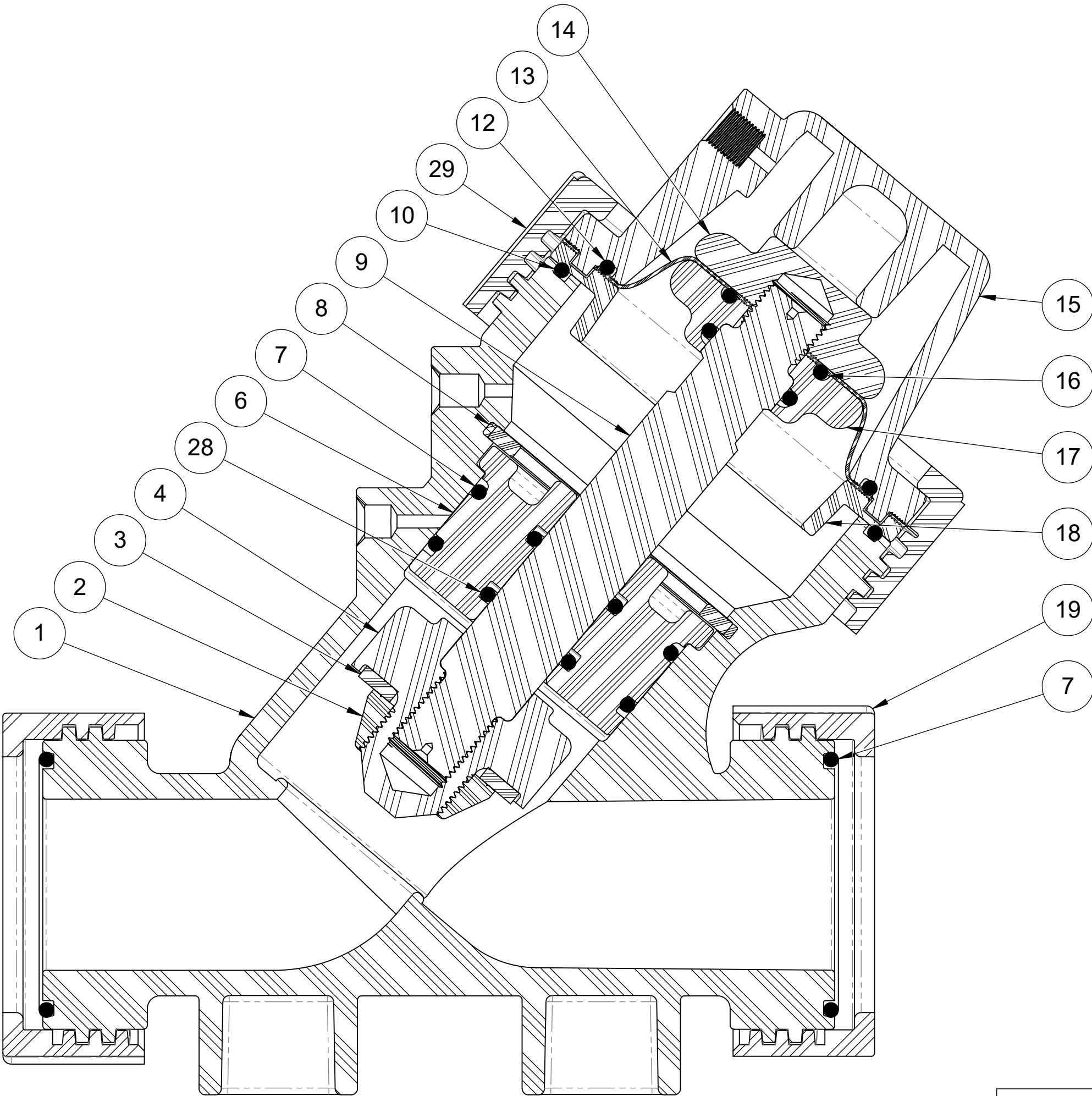

1070308 (K534-X200-14000)
NORMALLY OPEN (STANDARD)

CONNECTORS NOT FURNISHED WITH VALVE.
 SEE DRAWING 1084006 FOR FEMALE
 SOCKET WELD CONNECTORS.

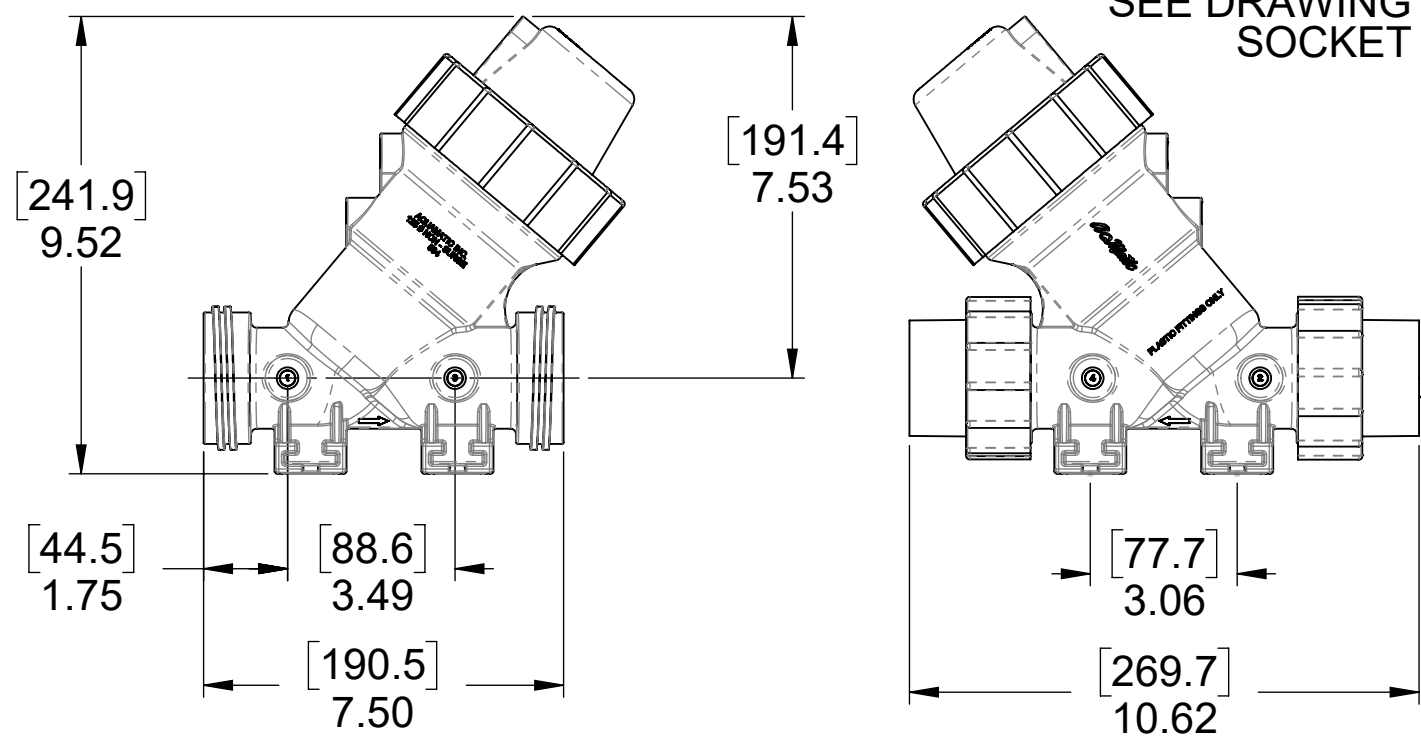

ASSEMBLY TOOLS	
DESCRIPTION	PART NO.
LIMIT STOP TOOL (NOT SHOWN)	1073556 (V560-579)

REPAIR PARTS KITS			
DESCRIPTION	PART NO.		
DIAPHRAGM & SEALS KIT CONSISTS OF ITEM NO'S 3, 5, 7, 10, 12, 13, 16	EPDM 1070319 (534-RAF) INCLUDES DIAPHRAGM 1073333	FKM 3003017 (534-RAVBF) INCLUDES DIAPHRAGM 1073333	BUTYL 1070327 (534-RAJ) INCLUDES DIAPHRAGM 1073333
INT. PARTS KIT CONSISTS OF ITEM NOS'S 2, 4, 6, 8, 9, 14, 17, 18	1070343 (K534-RF)		

SEE PAGE 2 FOR CONFIGURATION OPTIONS

THIS DOCUMENT IS SOLELY THE PROPERTY OF AQ-MATIC REPRODUCTION, USE DISCLOSURE, OR TRANSMISSION OF THIS DOCUMENT OR DETAILS CONTAINED HEREIN, IN PART OR IN WHOLE, IS PROHIBITED WITHOUT THE WRITTEN CONSENT OF AQ-MATIC ENGINEERING. THIS DOCUMENT AND ANY COPIES SHALL BE RETURNED TO AQ-MATIC UPON WRITTEN REQUEST.

INTERPRET DIMENSIONS AND TOLERANCES PER ASME Y14.5M -1994

UNLESS OTHERWISE SPECIFIED:
 DIMENSIONS ARE IN INCHES [mm]
 CORNER FILLETS R.005-020 [127-508]
 TOLERANCES:
 ANGLES: ± 1°
 1 PLACE .X: ± .100 [2.54]
 2 PLACE .XX: ± .010 [0.25]
 3 PLACE .XXX: ± .005 [0.13]

THE COMPONENT OR PRODUCT DESCRIBED IN THIS DOCUMENT MUST COMPLY WITH RoHS 3 EU (EUROPEAN UNION) DIRECTIVE 2015/863

THIRD ANGLE PROJECTION

APPROVALS: [Signature] DATE: 7/21/2020

DRAWN: PMJ

CHECKED BY:

APPROVED:

AQ-Matic AQ-MATIC VALVES AND CONTROLS

DESCRIPTION: **CATALOG SHEET, 534**

SIZE: C DWG NO.: 1077689 REV.: R

SCALE: 1:1 SOLIDWORKS FORMAT SHEET 1 OF 2

REVISIONS				
REV	ECN	DESCRIPTION	DATE	APP'D
SEE SHEET 1 FOR LIST OF CHANGES				

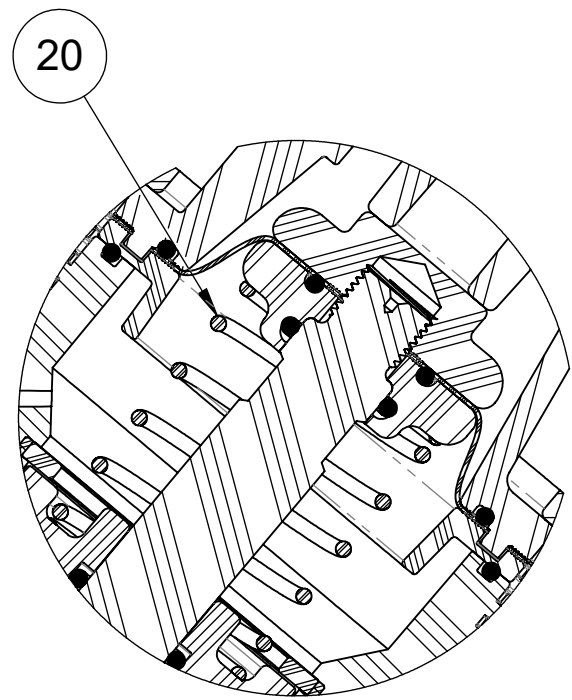

1071329 (K534-X201-14000)
SPRING ASSIST OPEN

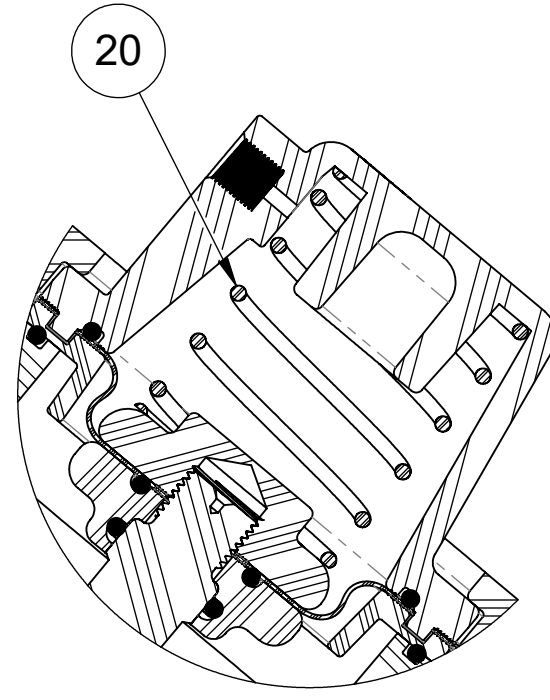

1071332 (K534-X202-14000)
SPRING ASSIST CLOSED

SPRING ASSIST CLOSED MODEL & SPRING ASSIST OPEN MODEL

ITEM	PART NO.	MODEL	DESCRIPTION	QTY
20	1073340	V534-170	SPRING, COMPRESSION, 534	1

LIMIT STOP MODEL

ITEM	PART NO.	MODEL	DESCRIPTION	QTY
21	1073345	V534-420K	CAP, 1-12 VALVE LS/PI, V534	1
22	1071673	ORB-018	O-RING, 2-018	BUNA N 1
23	1073368	V534-570	GUIDE, LS/PI, 534	1
24	1071668	ORB-012	O-RING, 2-012, NITRILE	BUNA N 1
25	1073373	V534-576	SCREW, LIMIT STOP, 534	1

LIMIT STOP POSITION INDICATOR MODEL

ITEM	PART NO.	MODEL	DESCRIPTION	QTY
21	1073345	V534-420K	CAP, 1-12 VALVE LS/PI, V534	1
22	1071673	ORB-018	O-RING, 2-018	BUNA N 1
23	1073368	V534-570	GUIDE, LS/PI, 534	1
24	1071668	ORB-012	O-RING, 2-012, NITRILE	BUNA N 1
26	1073362	V534-535	SHAFT, PI, 534	1
27	1073346	V534-442	PLATE, DIAPHRAGM, UPR, 534	1
28	1071666	ORB-006	O-RING, 2-006	BUNA N 1
29	1081128	V534-700	SCREW, LIMIT STOP, ASSY., 534	1
30	1073367	V534-555	ROD, PI, 534	1
31	1073365	V534-550	PI SIGHT GLASS, 534	1

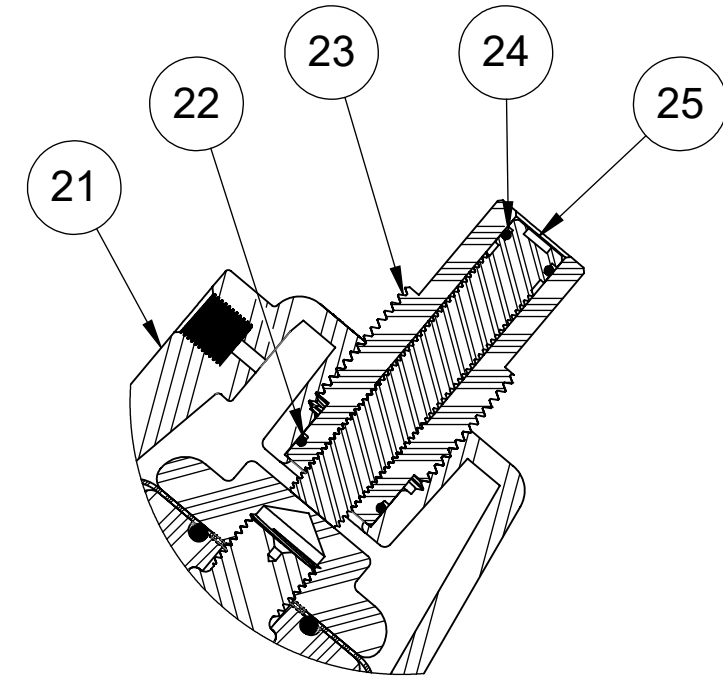

1070309 (K534-X210-14000)
LIMIT STOP

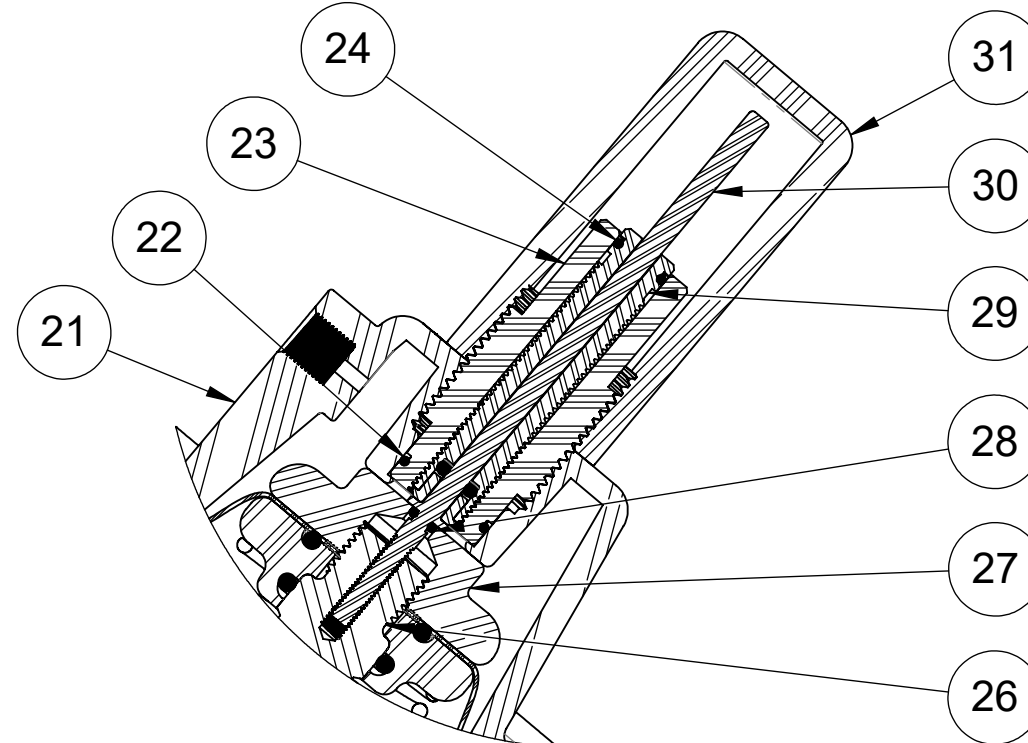

1071313 (K534-X2A1-14000)
**LIMIT STOP/
POSITION INDICATOR**

REPAIR PARTS KITS

DESCRIPTION	PART NO.
INT. PARTS KIT (SPRING ASSIST CLOSED) CONSISTS OF ITEM NO. 20	1075233 (534-S)
INT. PARTS KIT (SPRING ASSIST OPEN) CONSISTS OF ITEM NO. 20	
INT. PARTS KIT (LIMIT STOP) CONSISTS OF ITEM NO.'S 22 THRU 25	1075230 (534-LS)
INT. PARTS KIT (LIMIT STOP / POS. INDICATOR) CONSISTS OF ITEM NO.'S 22 THRU 24 & 26 THRU 31	1075231 (534-PI)

CONVERSION PARTS KITS

DESCRIPTION	PART NO.
CONVERSION KIT (SPRING ASSIST CLOSED) CONSISTS OF ITEM NO 20	1075233 (534-S)
CONVERSION KIT (SPRING ASSIST OPEN) CONSISTS OF ITEM NO 20	
CONVERSION KIT (LIMIT STOP) CONSISTS OF ITEM NO.'S 12 & 21 THRU 25	1071308 (K534-LSC)
CONVERSION KIT (POSITION INDICATOR) CONSISTS OF ITEM NO.'S 12, 21 THRU 24 & 26 THRU 31	1071309 (K534-PIC)

SEE SHEET 1 FOR STANDARD NORMALLY OPEN MODEL

THIS DOCUMENT IS SOLELY THE PROPERTY OF AQ-MATIC REPRODUCTION, USE DISCLOSURE, OR TRANSMISSION OF THIS DOCUMENT OR DETAILS CONTAINED HEREIN, IN PART OR IN WHOLE, IS PROHIBITED WITHOUT THE WRITTEN CONSENT OF AQ-MATIC ENGINEERING. THIS DOCUMENT AND ANY COPIES SHALL BE RETURNED TO AQ-MATIC UPON WRITTEN REQUEST.

INTERPRET DIMENSIONS AND TOLERANCES PER ASME Y14.5M -1994

UNLESS OTHERWISE SPECIFIED:
DIMENSIONS ARE IN INCHES [mm]
CORNER FILLETS R.005-020 [127-508]
TOLERANCES:
ANGLES: ± 1°
1 PLACE .X: ± .100 [2.54]
2 PLACE .XX: ± .010 [0.25]
3 PLACE .XXX: ± .005 [0.13]

THE COMPONENT OR PRODUCT DESCRIBED IN THIS DOCUMENT MUST COMPLY WITH RoHS 3 EU (EUROPEAN UNION) DIRECTIVE 2015/863

THIRD ANGLE PROJECTION

APPROVALS: _____ DATE: 7/21/2020

DRAWN: PMJ

CHECKED BY: _____

APPROVED: _____

AQ-Matic AQ-MATIC VALVES AND CONTROLS

DESCRIPTION: **CATALOG SHEET, 534**

SIZE: C DWG NO.: 1077689 REV.: R

SCALE: 1:2 SOLIDWORKS FORMAT SHEET 2 OF 2